

Kideas

Milk Carton Pirate Ship



Materials:

- 2 empty milk cartons
- all-purpose glue
- 2 sheets each black and brown construction paper (or color of your choice.)
- 2 popcicle sticks for plank (optional)
- 2 drinking straws, non-flex straws if possible.
- scissors
- hole punch
- 2 small globs of play dough

Directions:



1. Cut segment from bottom of one milk carton. Trace sides of milk carton and segment onto brown construction paper. Cut out pieces and glue onto segments as shown. Puncture two holes in square carton segment.

2. Embellish with black pieces of construction paper as shown.

3. Insert straws into square segment. Place small play dough blobs as shown to help hold straws in place. Place segment on top and glue to secure. Allow to dry.

4. Cut out the portholes below (or make your own), and glue on the side of your pirate ship.

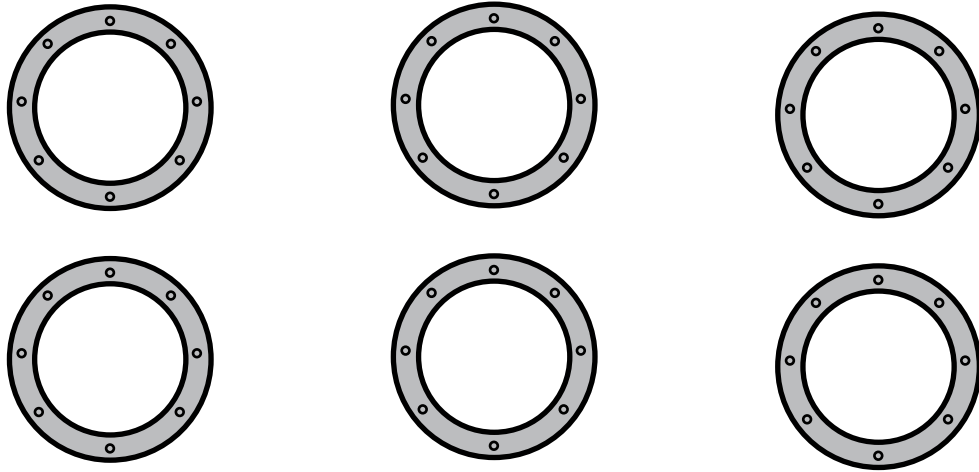

5. Cut out sails using the below pattern (or make your own, 2 of each)
Hole punch where indicated and insert onto straw masts.

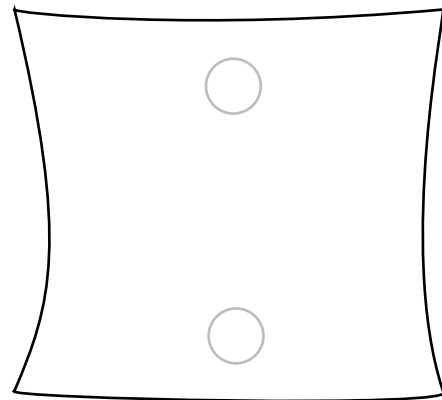
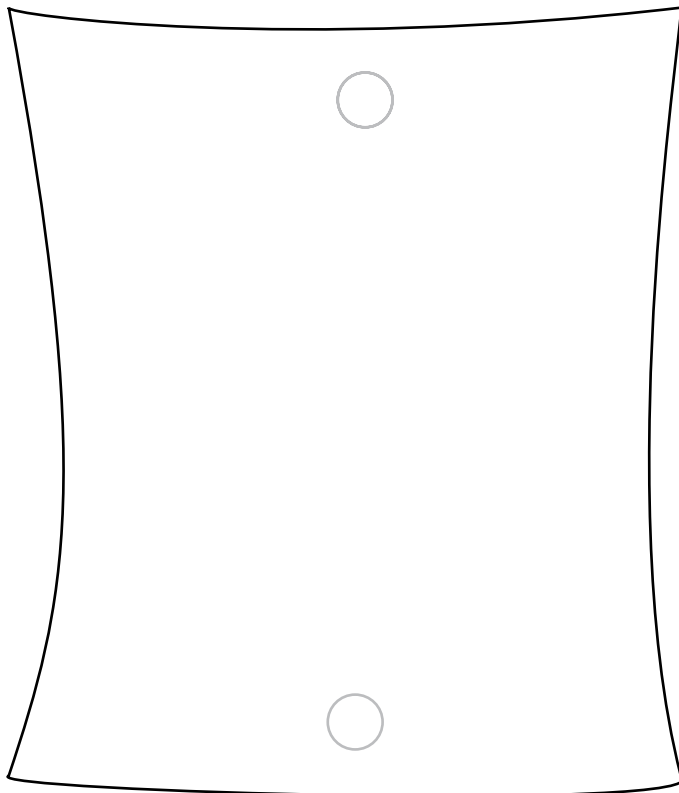

6. Cut out jolly roger pirate flag.
Fold over a rolled up scrap of construction paper or toothpick as a 'rod' and insert into one of the straws.

7. (optional) Glue two popsicle sticks together, after having nipped off the curved ends with scissors. Glue together as a 'plank' and place on pirate ship.

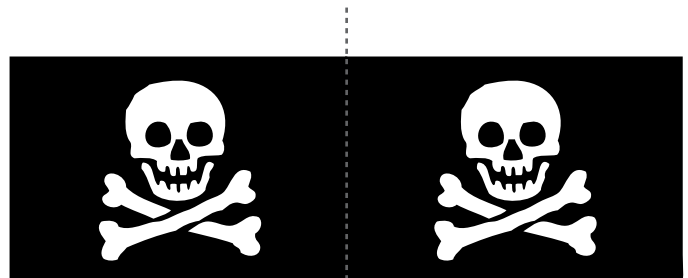

jolly roger - fold on dotted line

Ahoy, Mateys!